

850 Series 854F-E34TA Industrial Open Power Unit

EU Stage IV, EPA Tier 4 Final
75-86 kW / 101-115 hp

Building on its already strong EU Stage IIIB and EPA Tier 4 Final industrial range, Perkins is pleased to announce the continuing expansion of the 850 Series to include the new Industrial Open Power Units (IOPUs).

Perkins® IOPUs are industry leaders in flexibility, offering a wide choice of options to the customer. The whole unit has been built around the demands of our customers and as such offers a great package with a simple integration design.

The 854F-E34TA is a turbocharged, air-to-air chargecooled, 3.4 litre, 4 cylinder unit capable of producing 86 kW (115 hp). Its high power density, combined with excellent torque, enables the machine manufacturers to select this engine where previously they may have used an engine of higher cubic capacity. This downsizing creates more space to package the new aftertreatment unit, resulting in minimal installation impact for our customers.

The IOPUs are designed to be productive and have a new range of power ratings to ensure the customer maximises their profitability.

Perkins have developed a reputation for designing and building reliable and durable engines suitable for the most demanding applications.

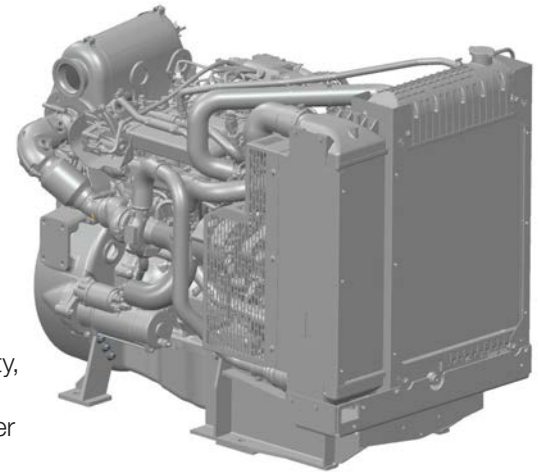

Emissions

Designed to meet 2014 Europe EU Stage IV and 2015 U.S. EPA Tier 4 Final emission requirements.

Specification		
Number of cylinders	4 vertical in-line	
Bore and stroke	99 x 110 mm	3.9 x 4.3 in
Displacement	3.4 litres	207.5 in ³
Aspiration	Turbocharged aftercooled	
Cycle	4 stroke	
Combustion system	Direct injection	
Compression ratio	17:1	
Rotation	Anti-clockwise, viewed on flywheel	
Cooling system	Liquid	
Total coolant capacity	16 litres	4.2 US gal

www.perkins.com

Photographs are for illustrative purposes only and may not reflect final specification.
All information in this document is substantially correct at time of printing and may be altered subsequently.
Final weight and dimensions will depend on completed specification.

Publication No. PN3101/04/15 Produced in England ©2015 Perkins Engines Company Limited

 **Perkins®**

THE HEART OF EVERY GREAT MACHINE

850 Series 854F-E34TA Industrial Open Power Unit

EU Stage IV, EPA Tier 4 Final
75-86 kW / 101-115 hp

Features and benefits

Reliable, quiet, and durable power

- World-class manufacturing capability and processes coupled with proven core engine designs assure reliability, quiet operation, and many hours of productive life

Innovative design

- Leading-edge technology of the 850 Series provides significant improvements in power, torque, fuel consumption and response
- Turbocharging – single smart wastegated turbo systems
- Durable high pressure common rail technology
- Centrifugal service-free filter, closed circuit breathing system

Fuel economy

- Fuel consumption optimised to match operating cycles of a wide range of equipment and applications.

Low cost of ownership

- Excellent fuel consumption
- Hydraulic tappets allow service-free top end
- Multi-vee belts for longer service intervals
- 500 hour oil change intervals
- Extended Service Contracts:
 - No surprises – Total protection from unexpected repair costs (parts, labour and travel)
 - Enjoy longer lasting product support from Perkins global network
 - Genuine Perkins parts ensure continued engine performance
 - Highly trained technicians carry out all repairs
 - Transferable coverage should you sell your machine

Discover more: www.perkins.com/esc

Product support excellence

- Perkins recognise that the customer relationship is important to machine manufacturers and we can offer a range of flexible solutions to help provide appropriate support, either to the OEMs' network or directly to the machine customer
- Perkins' information systems enable our distributors to quickly diagnose engine faults and identify the right parts. The Perkins logistics operation is able to dispatch more than 45,000 different parts from stock, reaching the customer within 24 hours
- To find your local distributor: www.perkins.com/distributor

www.perkins.com

Photographs are for illustrative purposes only and may not reflect final specification.
All information in this document is substantially correct at time of printing and may be altered subsequently.
Final weight and dimensions will depend on completed specification.

Publication No. PN3101/04/15 Produced in England ©2015 Perkins Engines Company Limited

 **Perkins**[®]

THE HEART OF EVERY GREAT MACHINE

850 Series 854F-E34TA Industrial Open Power Unit

EU Stage IV, EPA Tier 4 Final
75-86 kW / 101-115 hp

Technical information

Air inlet

- Standard air cleaners

Control system

- Full electronic control system
- Fully integrated, engine-mounted engine control module
- All connectors and wiring looms waterproof and designed to withstand harsh off-highway environments
- Flexible and configurable software features and J1939 standard communications I/O

Standard emissions control equipment

- NRS – NOx Reduction System

Flywheels and flywheel housing

- SAE3 configuration

Fuel system

- Electronic high pressure common rail
- Engine-mounted fuel filters

Power take-off

- SAE A flange on left-hand side

www.perkins.com

Photographs are for illustrative purposes only and may not reflect final specification.
All information in this document is substantially correct at time of printing and may be altered subsequently.
Final weight and dimensions will depend on completed specification.

Publication No. PN3101/04/15 Produced in England ©2015 Perkins Engines Company Limited

 **Perkins**[®]

THE HEART OF EVERY GREAT MACHINE

850 Series 854F-E34TA Industrial Open Power Unit

EU Stage IV, EPA Tier 4 Final
75-86 kW / 101-115 hp

Engine mounted aftertreatment – DOC and SCR mixer

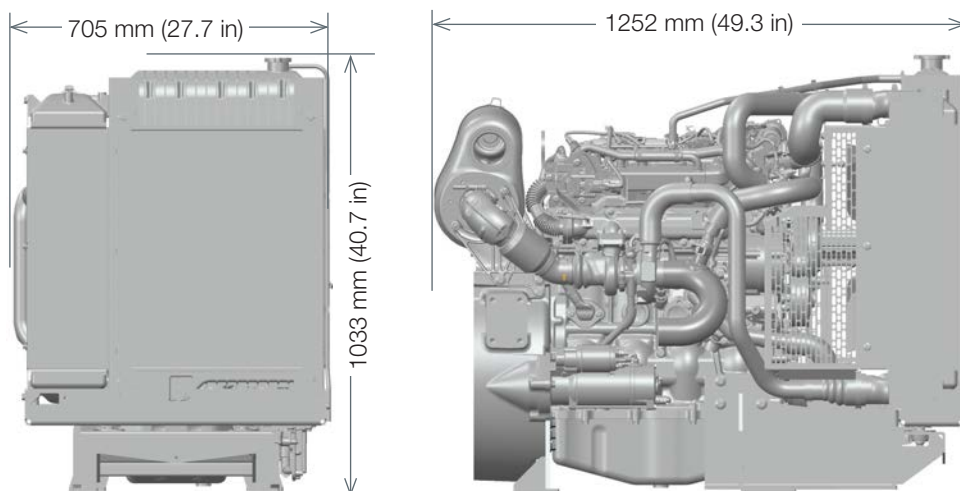

Engine package weights and dimensions

Engine package weights and dimensions		
Length	1161 mm	45.7 in
Width	957 mm	37.7 in
Height	705 mm	27.7 in
Weight (dry)	407 kg	897 lb

www.perkins.com

Photographs are for illustrative purposes only and may not reflect final specification.
All information in this document is substantially correct at time of printing and may be altered subsequently.
Final weight and dimensions will depend on completed specification.

Publication No. PN3101/04/15 Produced in England ©2015 Perkins Engines Company Limited

 **Perkins**[®]

THE HEART OF EVERY GREAT MACHINE

850 Series 854F-E34TA Industrial Open Power Unit

EU Stage IV, EPA Tier 4 Final
75-86 kW / 101-115 hp

DOC Mixer

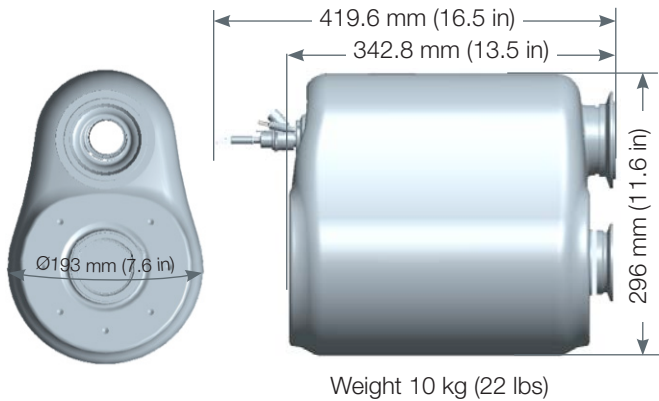

SCR Can

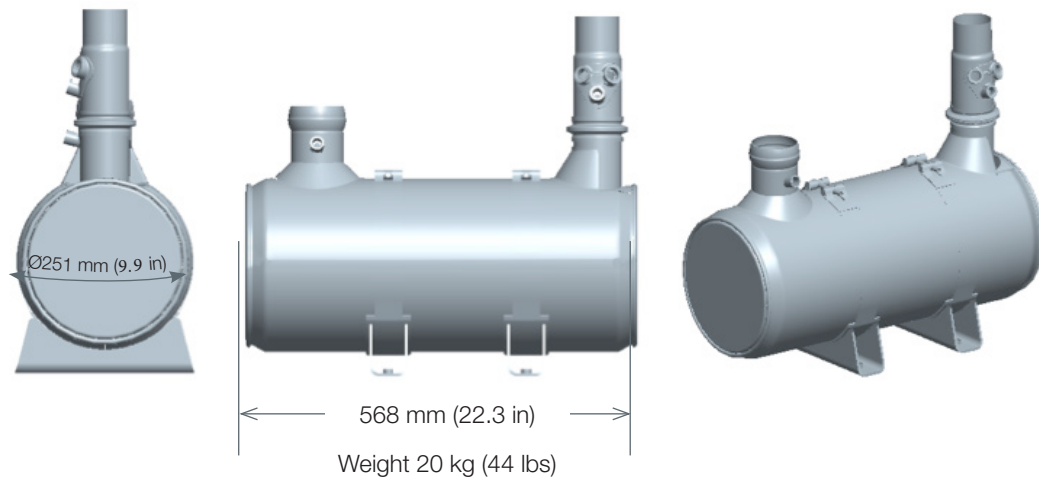

Aftertreatment

DOC	Diesel Oxidation Catalyst
SCR	Selective Catalytic Reduction supplied with a range of inlet and outlet options
SCR Auxiliaries	A range of tanks and heated lines are available

Technology

The DOC/SCR technology provides customer's with as compact as possible aftertreatment solution.

Power

Using our advanced research and development techniques we have perfectly matched the aftertreatment to the engine. The DOC/SCR is invisible to the operator whilst the machine is being used.

Mounting

DOC/mixer engine mounted. Flexibility of remote mounting of SCR can in various orientations.

Service

Aftertreatment is designed to be service free for the life of the engine.

www.perkins.com

Photographs are for illustrative purposes only and may not reflect final specification.
All information in this document is substantially correct at time of printing and may be altered subsequently.
Final weight and dimensions will depend on completed specification.

Publication No. PN3101/04/15 Produced in England ©2015 Perkins Engines Company Limited

 **Perkins**[®]

THE HEART OF EVERY GREAT MACHINE

850 Series 854F-E34TA Industrial Open Power Unit

EU Stage IV, EPA Tier 4 Final
75-86 kW / 101-115 hp

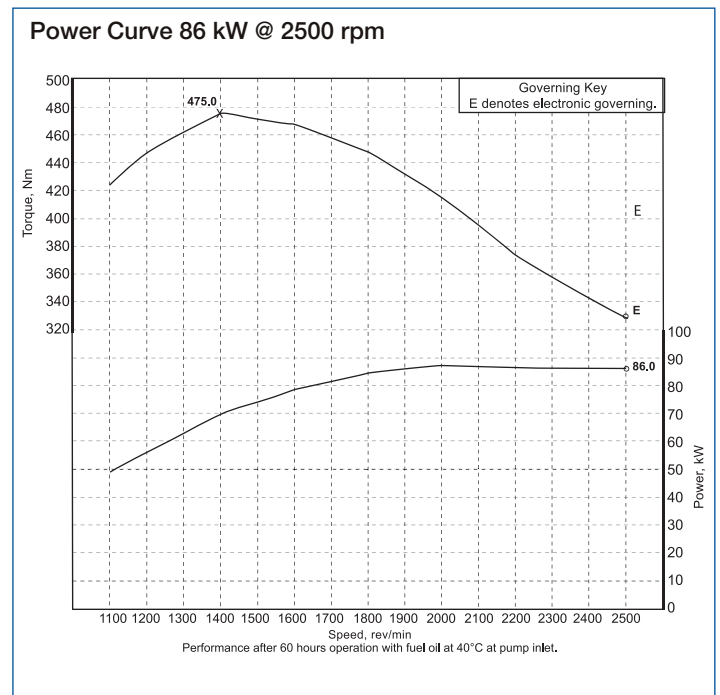
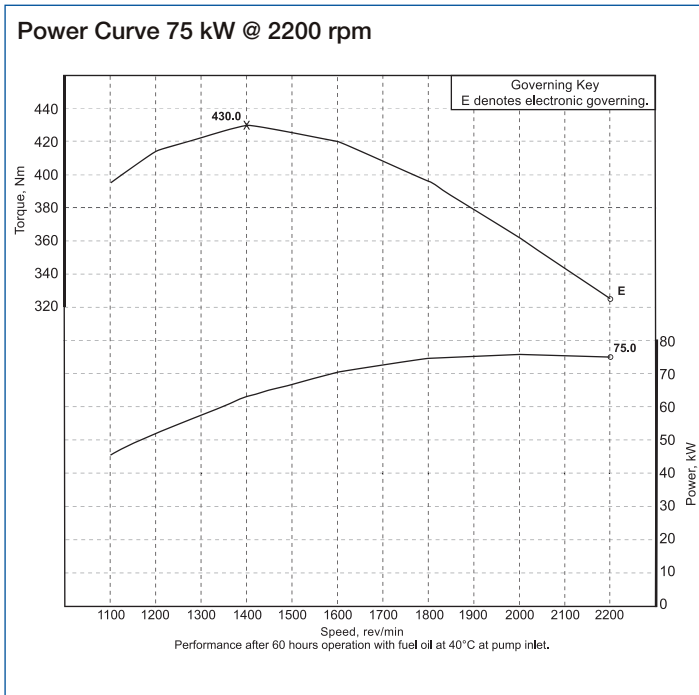

Rating Type	Speed rpm	Power kW	Power hp	Speed rpm	Torque Nm	Torque lb-ft
C	2200	75	101	1400	430	317
D	2500	86	115	1400	475	350

Rating definitions and conditions

IND-C (Intermittent) is the horsepower and speed capability of the engine where maximum power and/or speed are cyclic (time at full load not to exceed 50%).

Additional ratings are available for specific customer requirements. Consult your Perkins distributor.

IND-D for service where maximum power is required for periodic overloads (time at full load not to exceed 5% of the duty cycle).

Rating Conditions for Diesel Engines – up to 7.1 litres are based on ISO/TR14396, inlet air standard conditions with a total barometric pressure of 100 kPa (29.5 in. Hg), with a vapour pressure of 1 kPa (0.295 in Hg) and 25°C (77°F). Performance is measured using fuel to specification EPA 2D 89.330-96 with a density of 0.845-0.850 kg/L @ 15°C (59°F) and fuel inlet temperature 40°C (104°F).

www.perkins.com

Photographs are for illustrative purposes only and may not reflect final specification. All information in this document is substantially correct at time of printing and may be altered subsequently. Final weight and dimensions will depend on completed specification.

Publication No. PN3101/04/15 Produced in England ©2015 Perkins Engines Company Limited

Perkins®

THE HEART OF EVERY GREAT MACHINE