

# HANCO GENERATING SYSTEMS

## PRIME SERIES

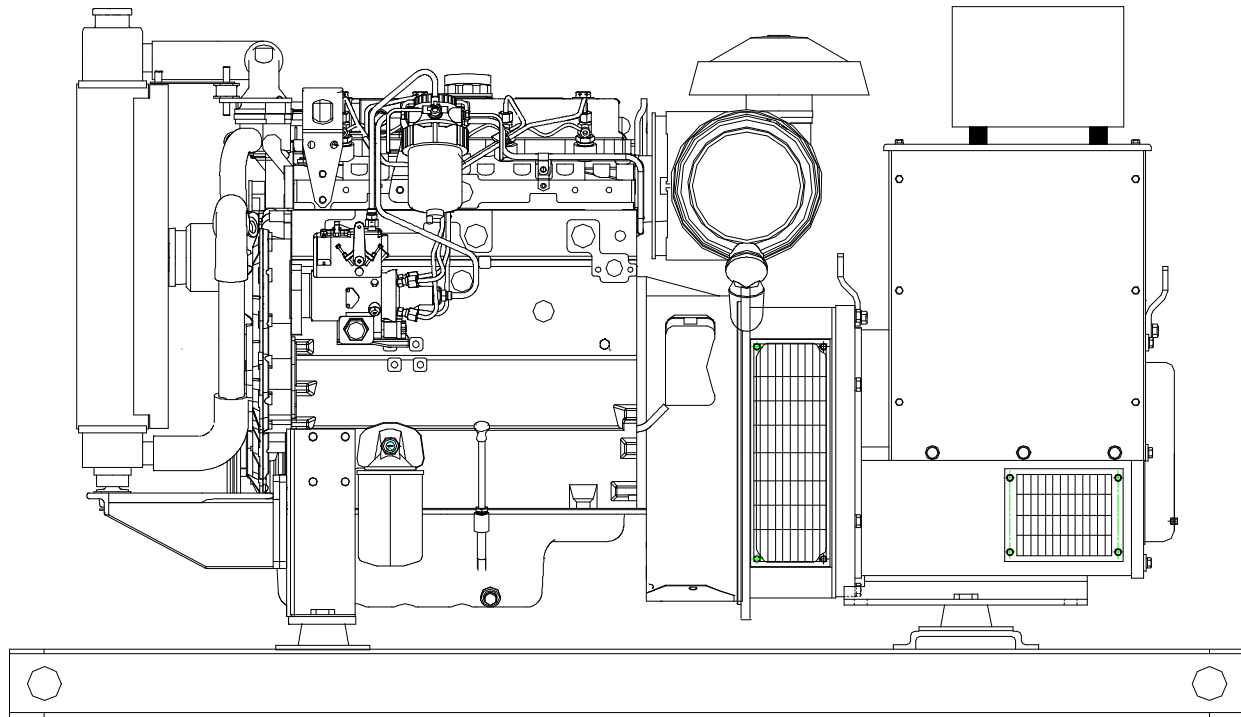

MODEL  
65MSF33DWLP  
60MSF22DWLP

### POWER RATINGS

65KW STANDBY  
60KW CONTINUOUS  
120/240 VOLT 1 PHASE 60 Hz  
271 AMPS @ 240V 1 PHASE  
3 PHASE RATINGS AVAILABLE  
12 LEAD RECONNECTABLE

### STANDARD SPECIFICATIONS

PERKINS DIESEL ENGINE MODEL 1004-40T  
HEAVY DUTY RADIATOR  
MECHANICAL GOVERNOR  
VIBRATION ISOLATORS  
HEAVY DUTY 2 STAGE AIR CLEANER  
12V ELECTRICAL SYSTEM  
INDUSTRIAL GRADE SILENCER  
ALTERNATOR EPOXY COATED  
SOLID STATE VOLTAGE REGULATOR

### HANCO CONTROL PANEL

12V ENGINE GAUGES  
HOUR METER, TEMP GAUGE, OIL PRESSURE  
A/C METERS, AMPS, VOLTS, HERTZ  
HIGH COOLANT TEMP SHUTDOWN  
LOW OIL PRESSURE SHUTDOWN  
CRANK/PRE HEAT START/STOP SWITCH

### OPTIONAL EQUIPMENT

AUTO START CONTROLS  
UL SUBBASE FUEL TANKS  
MAINLINE CIRCUIT BREAKER  
LOW AMP AUTO START FOR SOLAR

# Model

## 65MSF33DWLP / 60MSF22DWLP

### Engine Specifications

Engine Model	Perkins 1004-40T
Cont. HP @ 1800 RPM	101 HP
Number of Cylinders	4
Aspiration	Turbocharged
Displacement	243 cu in (3.99) litre
Bore / Stroke	3.937 (100) / 5.0 (127)
Engine Type	In-Line 4 Cylinder
Forged Steel Dynamically Balanced Crankshaft	
Rotary Injection Pump With Mechanical Gover-	

#### Shipping Characteristics of Basic Unit

Weight - 1934 lbs (no options)  
 Cube - L= 80" W= 34" H= 48" (no options)

Specification subject to change without notice

### Generator Specifications

Model	UCI274C
Rating @ Rise / Ambient	125F / 40 C
Insulation	Class H
Voltage Regulator	SX 460
Winding Leads	12 Lead Reconnectable
Voltage Regulation	Plus / Minus 1.5%

#### Fuel Consumption @ Rated Load

50%	2.9 US GAL / HR
75%	4.1 US GAL / HR
100%	5.4 US GAL / HR

#### Optional Equipment

2Wire auto start	Low amp start for Solar
Main Line Circuit Breaker	UL Subbase Tank
Electronic Governing	Weather Enclosure
Critical Grade Silencer	Auto Transfer Switch
SS Flex Connector	Sound Enclosure
Battery Trickle Charger	Trailer w/Fuel Cell

